

Data sheet
Karta katalogowa
Scheda di dati
Fiche Technique
Datenblatt

EN **Playground trampoline**
Outdoor vandal-proof trampoline

Description:

An outdoor trampoline is a vandal proof, digged into the ground device. The trampoline a single person use instrument, designed for adults and children use in public space e.g. schools, playgrounds, country parks and leisure centres, for all year round use. The jumping mat is made of a special, anti slip plastic blocks and is weather-resistant.

Device size: Ø 148 cm; Jumping mat size: Ø 84 cm;

Training effect: Jumping on the trampoline is a general development activity. It engages and activates whole body muscles, improving coordination, sense of balance, endurance, flexibility, and blood circulation. This motor efficiencies are necessary for the proper children development and for adults can be even a great way to reduce the weight.

Method of use:

Carefully come on the center of the jumping mat and start to jump using both your legs.

Exercise difficulty: Easy

Full safety of the equipment use can be maintained only as a result of regular control concerning damage and wear. Devices should be regularly checked for security and functionality.

The devices can be used by children from 5 years of age. Children should be supervised by guardians.

Intended for one person. Maximum weight of user 120 kg. Maximum jump height: 0,60 m.

Prepared on the basis of the following standards: PN-EN 1176-1:2017

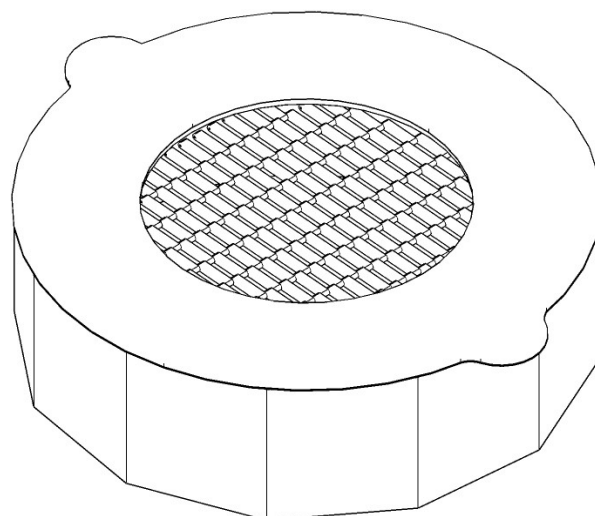
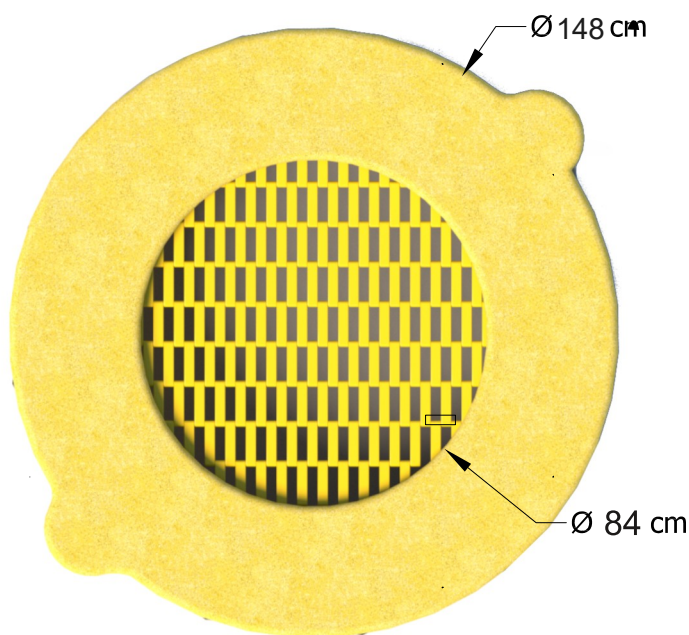

Maintenance manual
Instrukcja konserwacji
Manuel de maintenance
Manuale di manutenzione
Wartungshandbuch

EN

The inspection requires all parts of the trampoline, in particular: jumping bed, springs, safe surface and steel construction.

SPRINGS

If the springs shows any sign of excessive corrosion, deformation, excessive abrasion at the spring suspension over 15% of the spring wire thickness, cracks or other damage, the spring must be replaced immediately. If the trampoline bounce is weak probably you need to replace the springs. When springs are overstretched, they lose their memory and strength. In the removed spring the coils should touch together. If not, it means that the spring is overstretched because of overloading and needs to be replaced. Spring replacement should be considered as part of the maintenance routine. Use a spring hook to snap the springs.

JUMPING BED end PLASTIC PARTS

Plastic jumping bed elements are UV stabilised to provide a long trouble free life. However, after extended UV exposure some colour fading and material embrittlement can be expected. This will vary depending on the location and orientation of the products, but after a period of 1 years in normal environment, all products should be checked for signs of embrittlement and replaced as required. In case of break up of jumping bed block, steel rope or rope clamp the jumping bed should be replaced immediately. Wash with water and no aggressive detergent if dirty.

SURFACE

If safety surface cracking or peeled away from the structure it should be replaced.

CONSTRUCTION

Any damage or scratches in the coating surface identified should be made good within a month:

- clean area with a non-aggressive solvent.
- then immediately repaint using a suitable cold galvanizing application.

The area under the trampoline should be cleaned at least annually and its surface should be permeable to water. Puddles are not acceptable.

INSPECTIONS

Visual inspection device is intended to detect visible damage and risks that could arise for reasons such as: misuse, vandalism or weather conditions.

NOTE 1 For trampolines installed in areas with intensive and also in areas characterized to frequent damage caused by vandalism, may be required daily inspection.

NOTE 2 During the inspection routine and operational should pay attention to: cleanliness, level ground, state of the the surface, sharp edges, missing parts, worn and broken spring, excessive used (mobile and disperse the parts), structural strength of construction.

Operational control: More accurate than a routine inspection of facilities for checking the functionality and stability of exercise equipment. You should do this every 1 to 3 months according to guidance of Maintenance manual.

Main annual inspection: Control of defining the overall condition for safe exploiting of equipment (main annual review).

NOTE 3 Main annual inspection may need to dig or decompose (spin) of individual equipment or their parts. The annual inspection should be performed by the manufacturer or an authorized repairer 1MOVE. Submissions annual inspection the following address: 1@1move.pl

Failures in the absence of damage or exploiting of the device must be immediately replaced or repaired. If this is not possible, secure the unit before use. Contact the site 1MOVE: 1@1move.pl. Use only original spare parts. Repair and replacement of parts may only make the manufacturer or its authorized representative.

Playground Trampoline

1MOVE

1M-T-FR

Impact Area
Strefa upadku
Zone d'Impact
Area de Impacto
Fallraum

11,6 m²

Required surface: lawn, bark mulch, woodchip, sand, gravel
Wymagana nawierzchnia: gleba, trawnik, mulcz z kory, drobno pokrojone kawaiki drewna, piasek, żwir
Requis de surface: la pelouse, le paillis d'écorce, copeaux de bois, sable, gravier
Superficiale necessaria: erba, pacciame di corteccia, finemente tritato pezzi di legno, sabbia, ghiaia
Erforderliche Oberflächen: Gras, Rindenmulch, fein gehackt Holzstcke, Sand, Kies

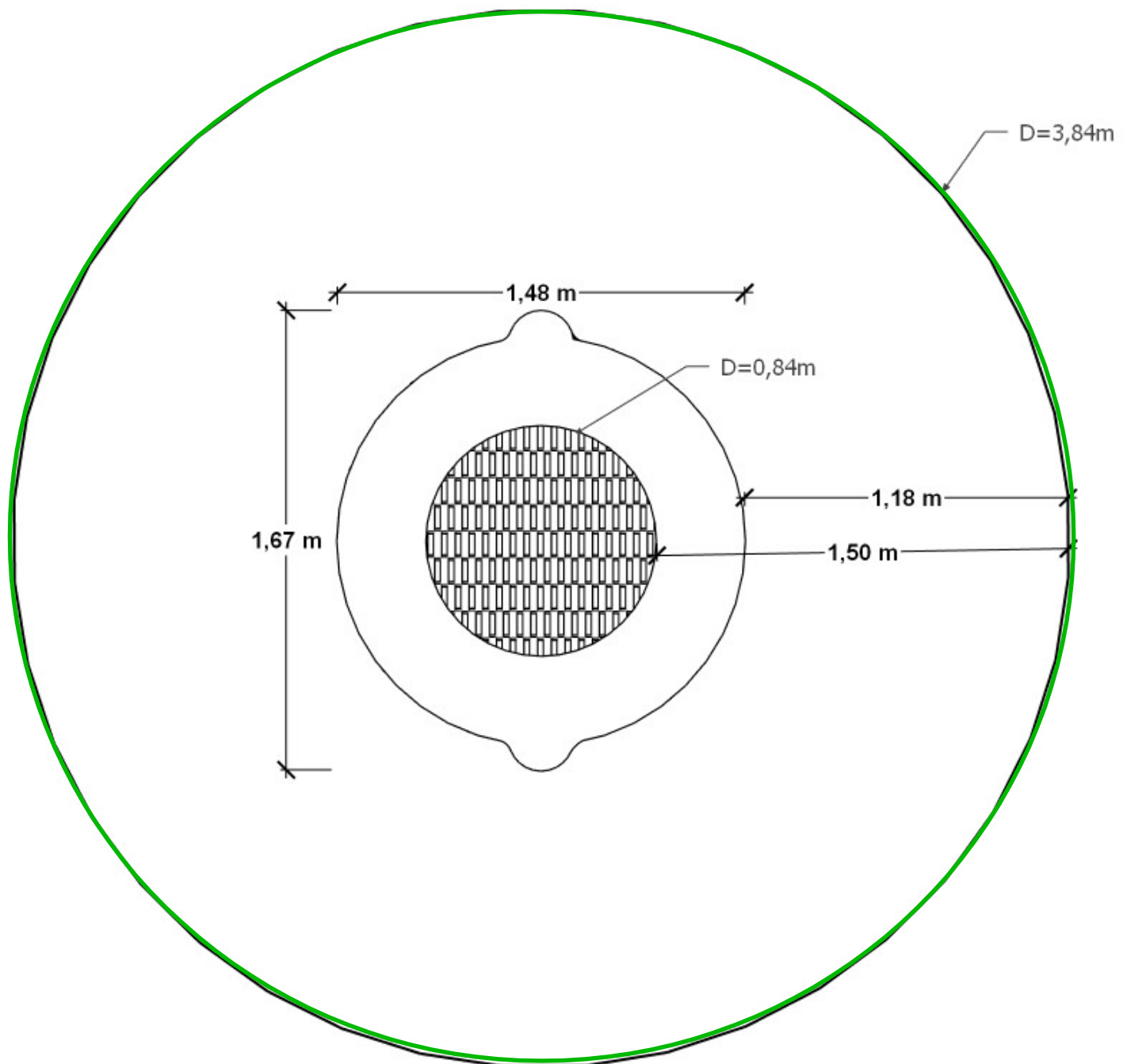

Starmax Marek Starczewski
Rycerska 3 st.
83-050 Bakowo, Poland
fitness@outdoorfitness.pl
tel.: +48 884-000-884 (PL/DE)
tel.: +48 600-250-245 (EN/RU)
www.outdoorfitness.pl



1MOVE

Playground Trampoline

1MOVE

1M-T-FR

Footing plan
Plan fundamentowania
Implanation
Implanación
Fundamentplan

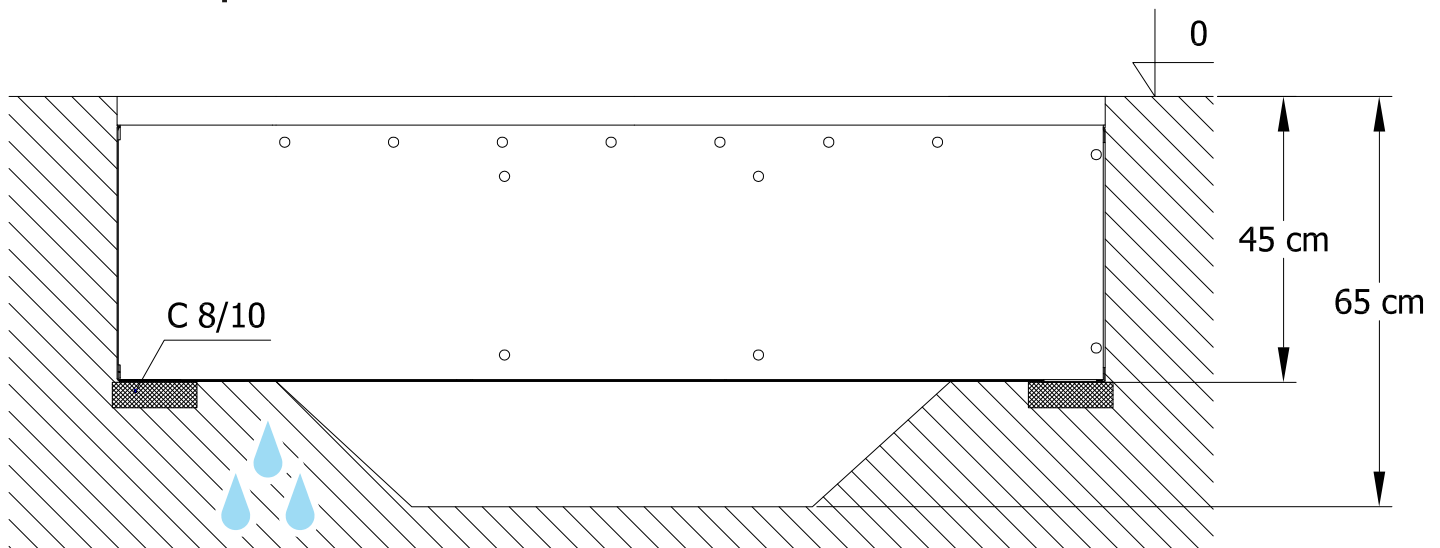

Drained undersoil / Podłoże wodoprzepuszczalne / Дренажная подсыпь

Starmax Marek Starczewski
Rycerska 3 st.
83-050 Bakowo, Poland
fitness@outdoorfitness.pl
tel.:+48 884-000-884 (PL/DE)
tel.:+48 600-250-245 (EN/RU)
www.outdoorfitness.pl



1MOVE