

Data sheet
Karta katalogowa
Scheda di dati
Fiche Technique
Datenblatt

EN

A workout tower consists of 4 horizontal bars 120 cm in length and is used to perform exercises in a hanging position. The bars are installed at different heights and form a square. They enable to perform exercises at the beginner and advanced level.

Height of bars: 260 cm, 240 cm, 210cm, 160 cm.

Considering the specifics of the equipment, there is a possibility of mounting the bars at different heights ranging from 30 cm to 260 cm.

Surface: Safety surface required

The devices can be used by adults and children from 14 years of age.

Maximum weight of user 120 kg.

Prepared on the basis of the following standards: PN-EN 1176-1:2009.

Manufactured in Poland.

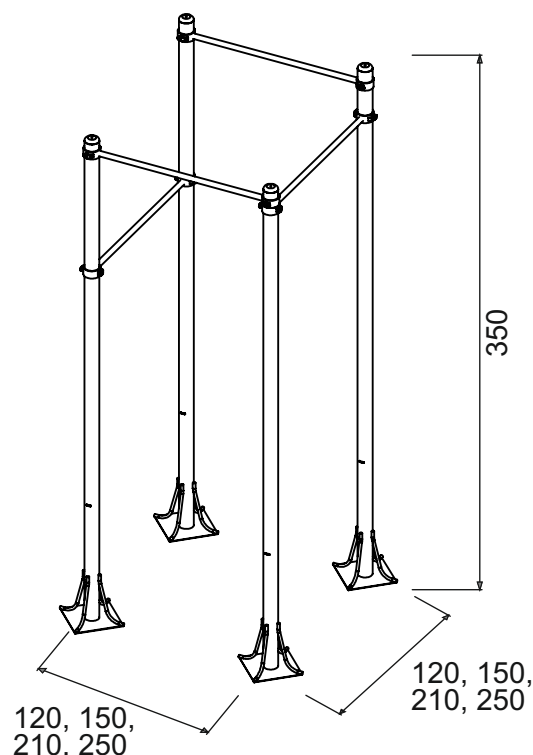
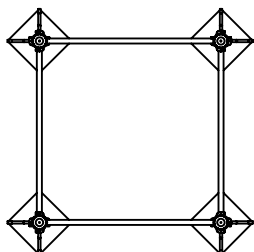

Maintenance manual
Instrukcja konserwacji
Manuel de maintenance
Manuale di manutenzione
Wartungshandbuch

EN

A inspection is carried out as follows:

Routine inspection:

Visual inspection device is intended to detect visible damage and risks that could arise for reasons such as: misuse, vandalism or weather conditions.

NOTE 1 For outdoor fitness installed in areas with intensive use of equipment, and also in areas characterized to frequent damage caused by vandalism, may be required daily inspection.

NOTE 2 During the inspection routine and operational should pay attention to: cleanliness, level ground state of the ground, exposed (mobile) foundations, sharp edges, missing parts, excessive used (mobile and disperse the parts), structural strength of construction.

Operational control:

More accurate than a routine inspection of facilities for checking the functionality and stability of exercise equipment. You should do this every 1 to 3 months according to guidance of manufacturer.

Main annual inspection:

Control of defining the overall condition for safe exploiting of equipment (main annual review).

NOTE 3 Main annual inspection may need to dig or decompose (spin) of individual equipment or their parts.

The annual inspection should be performed by the manufacturer or an authorized repairer 1-MOVE. Submissions annual inspection the following address:

1@1move.pl

Failures

In the absence of damage or exploiting of the device must be immediately replaced or repaired. If this is not possible, secure the unit before use. Contact the site 1-MOVE Center: 1@1move.pl.

Use only original spare parts. Repair and replacement of parts may only make the manufacturer or its authorized representative.

WORKOUT TOWER

1M - 1.01.A, 1M - 1.01.B
1M - 1.01.C, 1M - 1.01.D

Installation manual
Instrukcja instalacji
Manuel d'installation
Manuale di installazione
Installationshandbuch

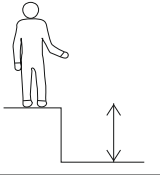
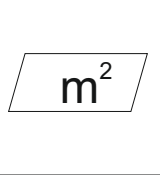
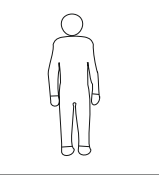
		
2,40 m	32-48	14 → +

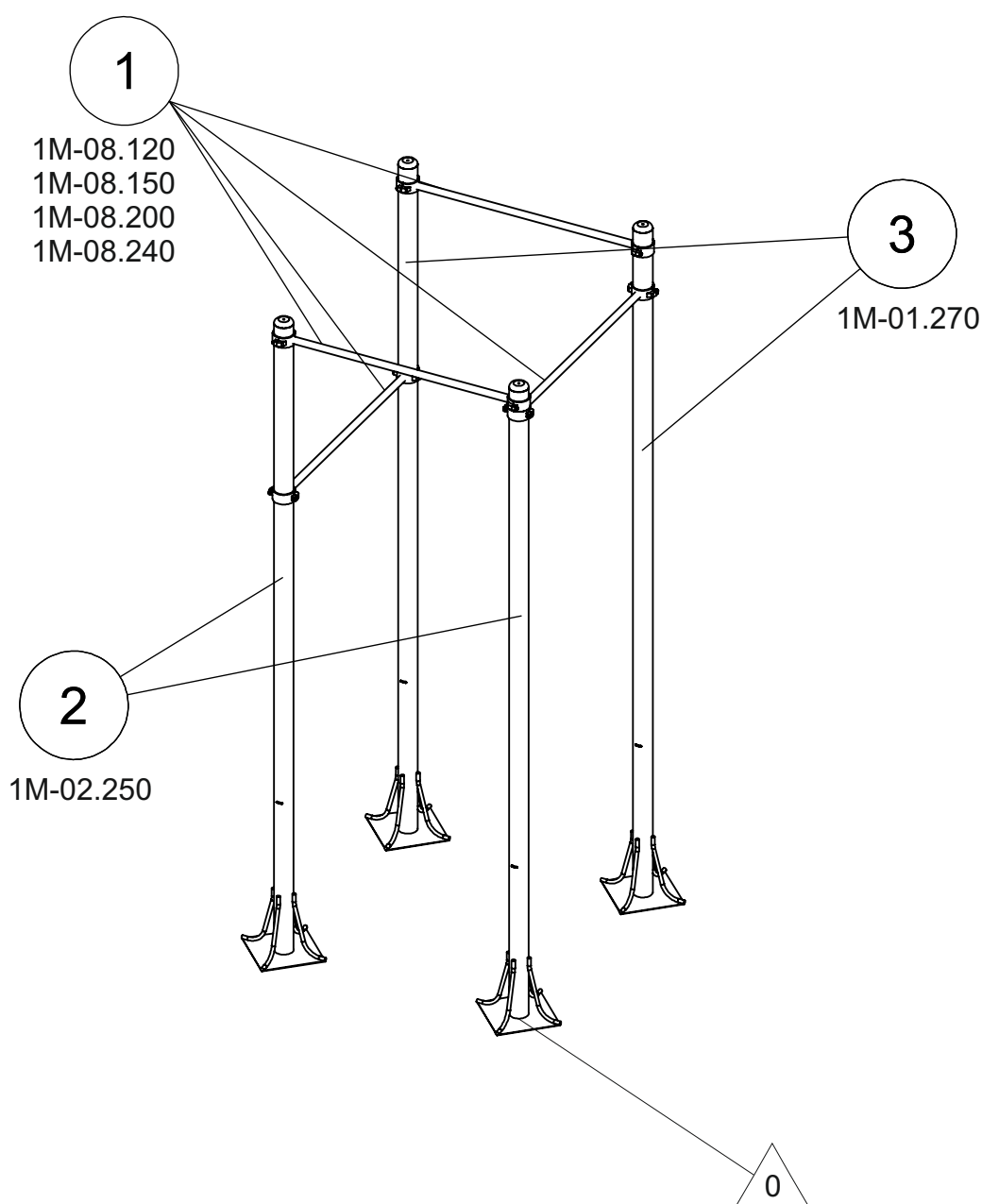

WORKOUT TOWER

1M - 1.01.A, 1M - 1.01.B
1M - 1.01.C, 1M - 1.01.D

Impact Area ———
Strefa opadku
Zone d'Impact
Area de Impacto
Fallraum

32 m²

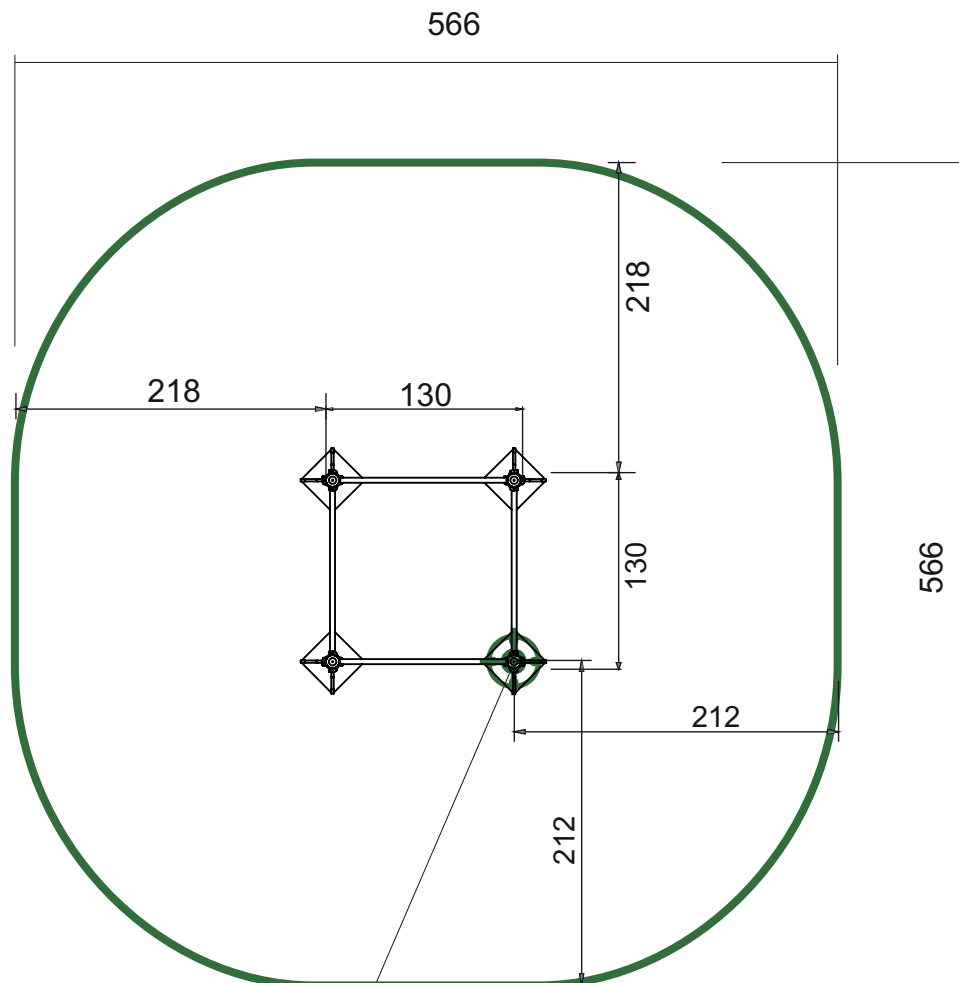

Setting Out Point
Punkt odniesienia
Point de Référence
Punto de referencia
Bezugspunkt

WORKOUT TOWER

1M - 1.01.A, 1M - 1.01.B
1M - 1.01.C, 1M - 1.01.D

Impact Area ———
Strefa opadku
Zone d'Impact
Area de Impacto
Fallraum

35 m²

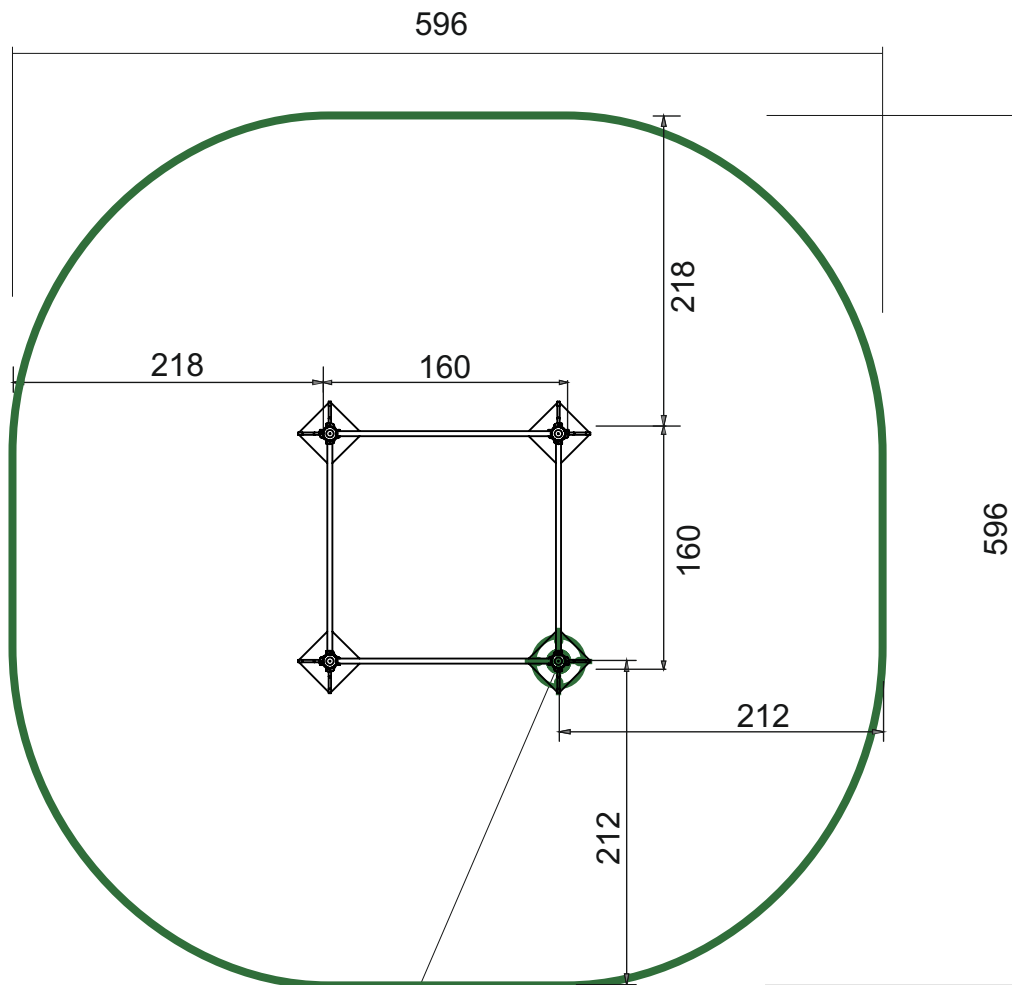

Setting Out Point
Punkt odniesienia
Point de Référence
Punto de referencia
Bezugspunkt

WORKOUT TOWER

1M - 1.01.A, 1M - 1.01.B
1M - 1.01.C, 1M - 1.01.D

Impact Area ———
Strefa opadku
Zone d'Impact
Area de Impacto
Fallraum

41 m²

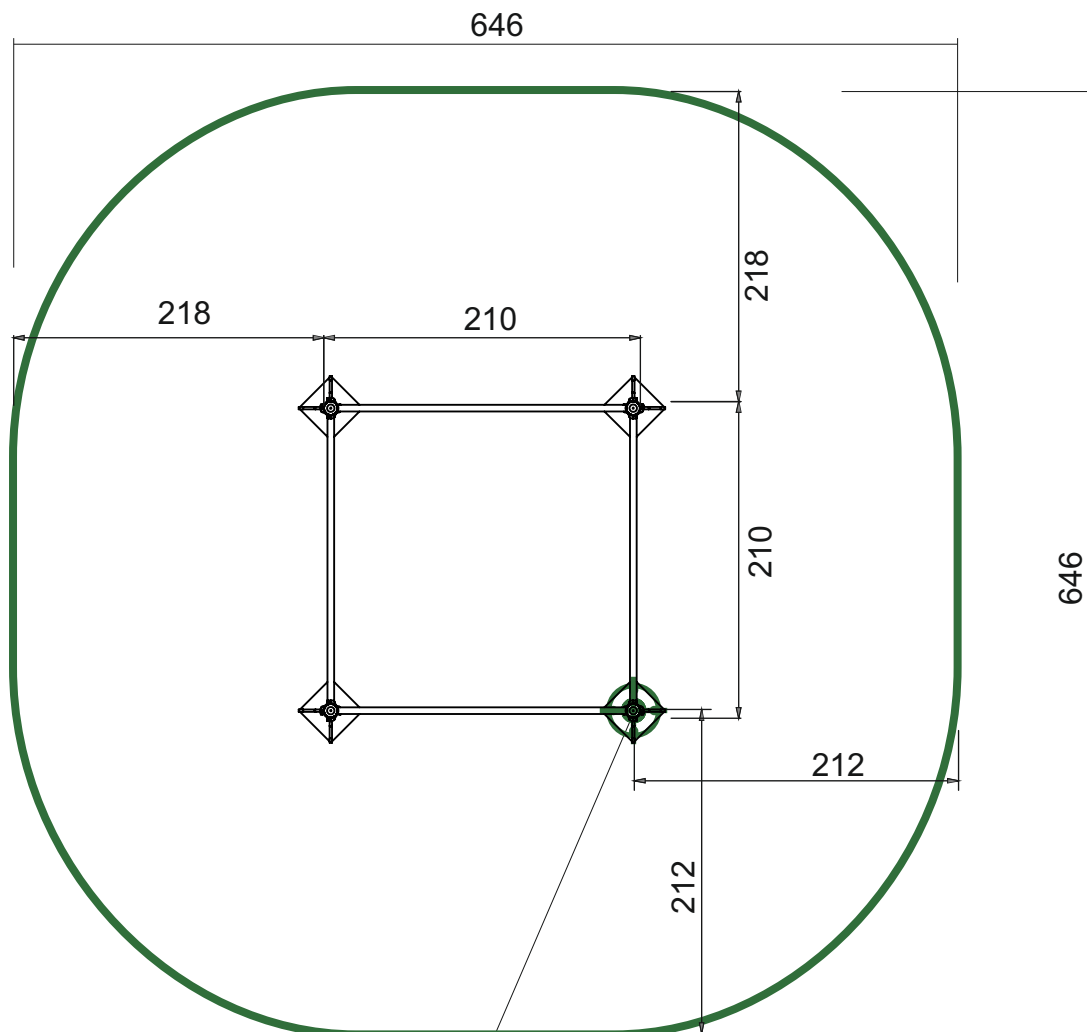

Setting Out Point
Punkt odniesienia
Point de Référence
Punto de referencia
Bezugspunkt

WORKOUT TOWER

1M - 1.01.A, 1M - 1.01.B
1M - 1.01.C, 1M - 1.01.D

Impact Area ———
Strefa opadku
Zone d'Impact
Area de Impacto
Fallraum

48 m²

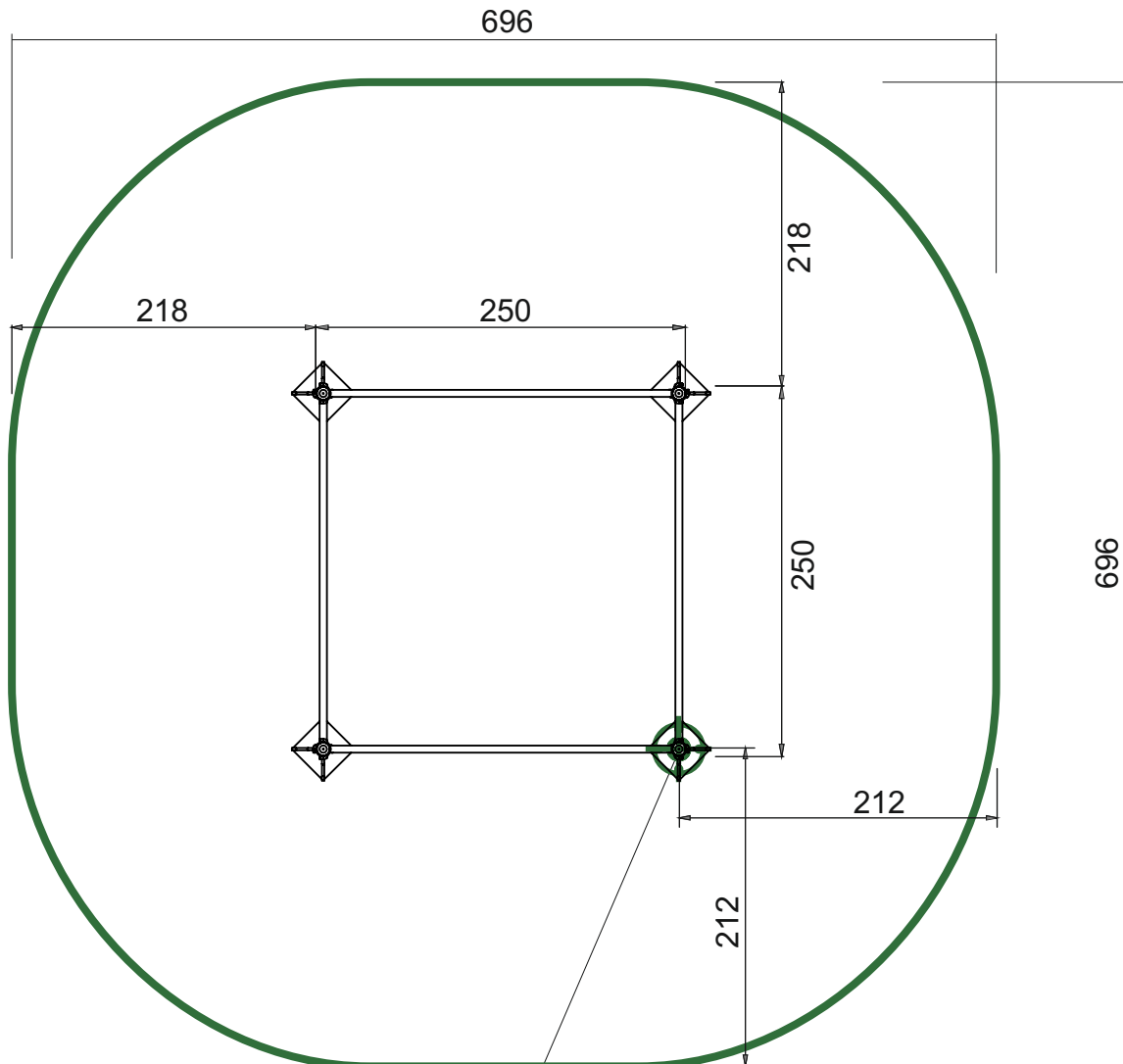

Setting Out Point
Punkt odniesienia
Point de Référence
Punto de referencia
Bezugspunkt

WORKOUT TOWER

1M - 1.01.A, 1M - 1.01.B
1M - 1.01.C, 1M - 1.01.D

Concrete pad 
Fundament betonowy
Dalle béton
Solera de Hormigón
Beton Bodenplatte

1 m² / 0,5 m³

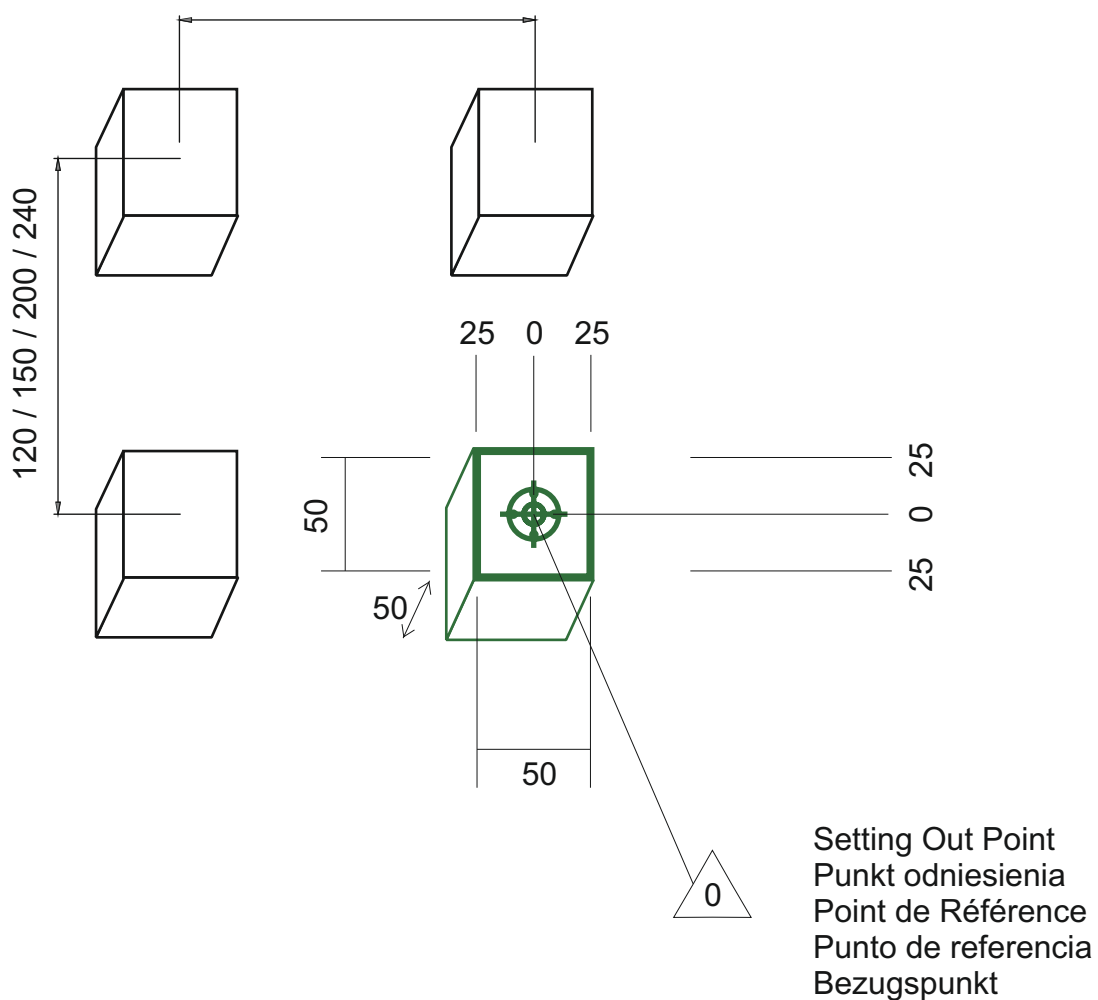

WORKOUT TOWER

1M - 1.01.A, 1M - 1.01.B
1M - 1.01.C, 1M - 1.01.D

Footing plan
 Plan fundamentowania
 Implanation
 Implanación
 Fundamentplan

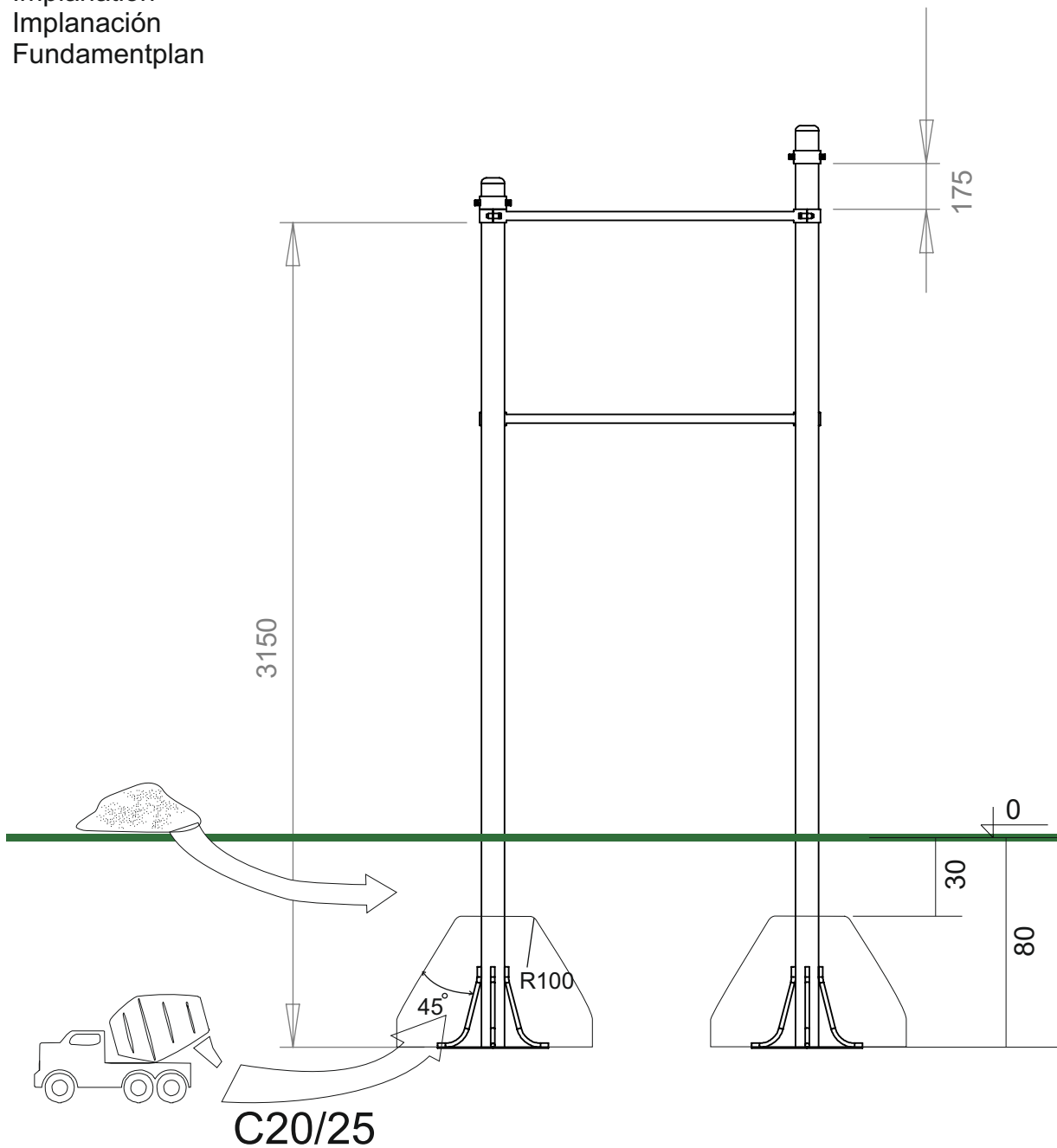

<p>16xM12x35 DIN 912</p>	<p>16xM12 DIN 1587</p>	<p>16xM16</p>	<p>24</p>	<p>2x</p>	
------------------------------	----------------------------	---------------	-----------	-----------	--